



**Installation Instructions & Owner's Manual**

**Evolve ES Series®**

Water Softeners



**For Models:**  
• ES

# TABLE OF CONTENTS

Pre-installation Instructions for Dealers .....	3
Bypass Valve .....	4
Installation .....	5
Programming Procedures .....	7
Start-up Instructions .....	8
Operating Displays and Maintenance .....	9
Troubleshooting Guide .....	11
Replacement Parts .....	16
Installation Fitting Assemblies .....	22
Specifications .....	23
Warranty .....	24
Quick Reference Guide .....	25

## YOUR WATER TEST

Hardness \_\_\_\_\_ gpg  
Iron \_\_\_\_\_ ppm  
pH \_\_\_\_\_ number  
\*Nitrates \_\_\_\_\_ ppm  
Manganese \_\_\_\_\_ ppm  
Sulphur \_\_\_\_\_ yes/no  
Total Dissolved Solids \_\_\_\_\_

\*Over 10 ppm may be harmful for human consumption.  
Water conditioners do not remove nitrates or coliform bacteria,  
this requires specialized equipment.

Look for our  
Evolve  
instructional  
videos on



## PRODUCT INFORMATION

Installing Dealer must fill out this information prior to unit installation

MODEL NUMBER \_\_\_\_\_

SERIAL NUMBER \_\_\_\_\_

DEALER INFORMATION:

\_\_\_\_\_  
\_\_\_\_\_  
\_\_\_\_\_

Your Evolve Series softener is a precision built, high quality product. These units will deliver softened water for many years to come when installed and operated properly. Please study this manual carefully and understand the cautions and notes before installing. This manual should be kept for future reference. If you have any questions regarding your water softener, contact your local dealer.

# PRE-INSTALLATION INSTRUCTIONS

The manufacturer has preset the water treatment unit's sequence of cycles, cycle times, salt dose, exchange capacity and salt dose refill time.

## THE DEALER SHOULD...

- Read this page and guide the installer regarding hardness, day override and time of regeneration.

## THE INSTALLER SHOULD...

- Program installer settings including hardness, day override, and time of regeneration.
- Read Operating Displays and Maintenance section.
- Set the time of day
- Read Power Loss and Error Display section.
- Ensure that system and installation are in compliance with all state and local laws and regulations.

## THE HOMEOWNER SHOULD...

- Read Programming Procedures section.
- Read Operating Displays and Maintenance section.

## GENERAL OPERATING DISPLAYS & NAVIGATION

During normal operation, the default user displays are "time of day" and "gallons per minute". Flow rate, capacity remaining, and days to a regeneration are optional displays. For more explanation, consult the "operating displays and maintenance section". Pressing the **NEXT** button on a general operating screen will cycle through the available operating displays.

In any screen other than a general operating display, the **NEXT** button will proceed to the next step, the **REGEN** button will return to a previous step, and the **CLOCK** button will return to the general operating displays. Any changes made prior to the exit will be incorporated. If no buttons are pressed within five minutes, the display will return to the general operating displays.

## DOUBLE REGENERATION

Two generations within 24 hours are possible with a return to the preset program. To initiate a double regeneration:

1. Press the **REGEN** button once. "REGEN TODAY" will flash on the display.
2. Press and hold the **REGEN** button for three seconds until a regeneration begins.

Once the valve has completed the immediate regeneration, the valve will regenerate once more during the preset time.

# BYPASS VALVE

The bypass valve is typically used to isolate the control valve from the plumbing system's water pressure in order to perform control valve repairs or maintenance. The 1" full flow bypass valve incorporates four positions, including a diagnostic position that allows a service technician to have pressure to test a system while providing untreated bypass water to the building. Be sure to install bypass valve onto main control valve before beginning plumbing or make provisions in the plumbing system for a bypass. The bypass body and rotors are glass-filled Noryl® and the nuts and caps are glass-filled polypropylene. All seals are self-lubricating EPDM to help prevent valve seizing after long periods of non-use. Internal "O" Rings can easily be replaced if service is required.

The bypass consists of two interchangeable plug valves that are operated independently by red arrow shaped handles. The handles identify the direction of flow. The plug valves enable the bypass valve to operate in four positions.

- 1. NORMAL OPERATION POSITION:** The inlet and outlet handles point in the direction of flow indicated by the engraved arrows on the control valve. Water flows through the control valve for normal operation of a water softener or filter. During the regeneration cycle this position provides regeneration water to the unit, while also providing untreated water to the distribution system (**Fig. 1**).
- 2. BYPASS POSITION:** The inlet and outlet handles point to the center of the bypass. The system is isolated from the water pressure in the plumbing system. Untreated water is supplied to the building (**Fig. 2**).
- 3. DIAGNOSTIC POSITION:** The inlet handle points toward the control valve and the outlet handle points to the center of bypass valve. Untreated supply water is allowed to flow to the system and to the building, while not allowing water to exit from the system to the building (**Fig. 3**). This allows the service technician to test the unit and perform other functions without disrupting the water going to the building.

**NOTE: The system must be rinsed before returning the bypass valve to the normal position.**

- 4. SHUT OFF POSITION:** The inlet handle points to the center of the bypass valve and the outlet handle points away from the control valve. The water is shut off to the building. The water treatment system will depressurize upon opening a tap in the building. A negative pressure in the building combined with the unit being in regeneration could cause a siphoning to the building. If water is available on the outlet side of the unit, it is an indication of water bypassing the system (**Fig. 4**) (i.e. a plumbing cross-connection somewhere in the building).

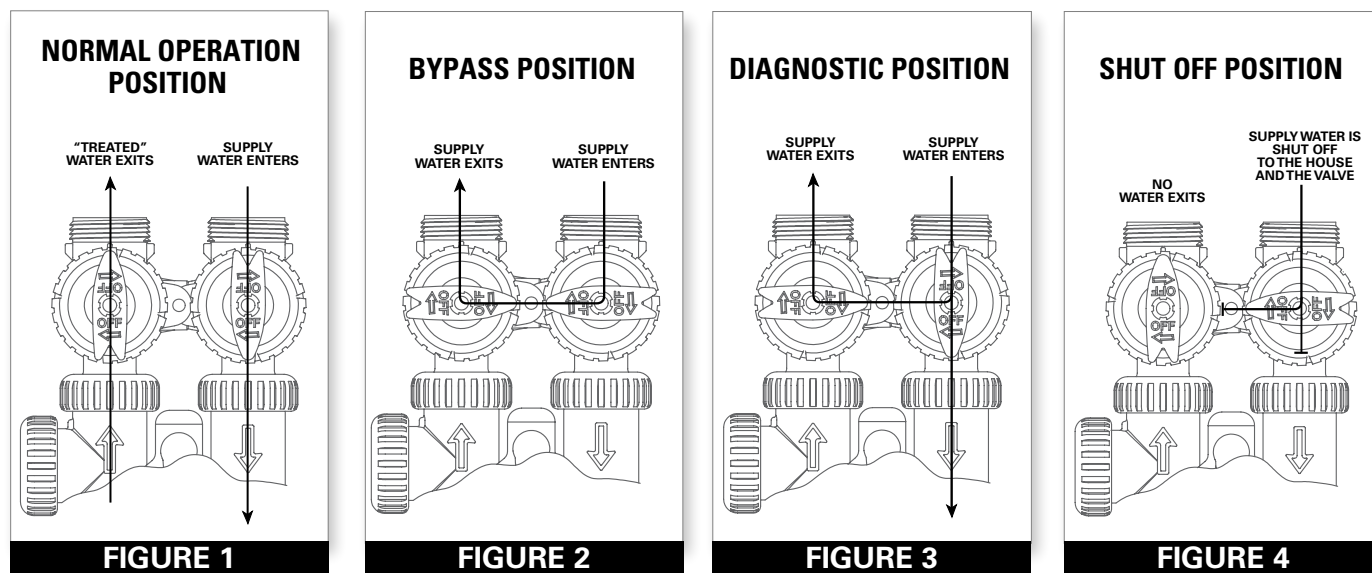

# INSTALLATION

## GENERAL INSTALLATION & SERVICE WARNINGS

The control valve, fittings and/or bypass are designed to accommodate minor plumbing misalignments. There is a small amount of “give” to properly connect the piping, but the water treatment unit is not designed to support the weight of the plumbing.

Do not use Vaseline, oils, other hydrocarbon lubricants, or spray silicone anywhere. A silicone lubricant may be used on black “O” Rings, but is not necessary. **Avoid any type of lubricants, including silicone, on red or clear lip seals.**

**Do not use pipe dope or other sealants on threads.** Teflon® tape must be used on the threads of the 1” NPT inlet and outlet and on the threads for the drain line connection. Teflon® tape is not used on the nut connections or caps because “O” Ring seals are used. The nuts and caps are designed to be unscrewed or tightened by hand or with the special plastic Service Wrench, #CV3193-02. If necessary, pliers can be used to unscrew the nut or cap. Do not use a pipe wrench to tighten nuts or caps. **Do not place screwdriver in slots on caps and/or tap with a hammer.**

## SITE REQUIREMENTS

- Water pressure – 30-100 psi
- Water temperature – 33-100°F (0.5-37.7°C)
- Electrical – 115/120V, 60Hz uninterrupted outlet
- Current draw is 0.5 amperes
- The plug-in transformer is for dry locations only

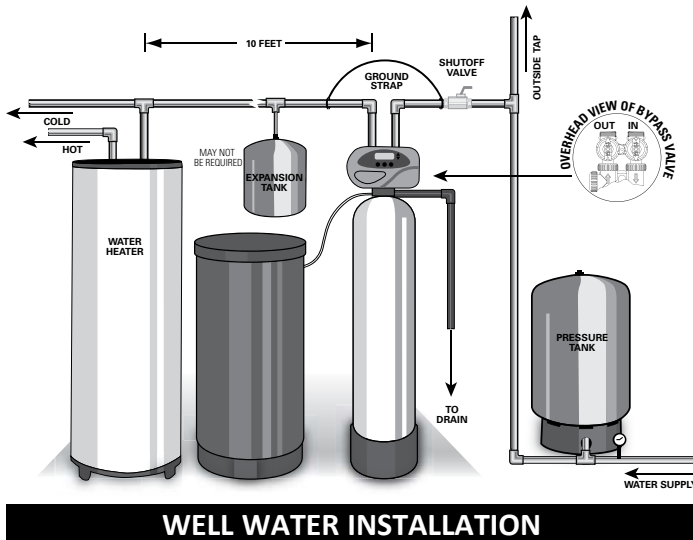

**WELL WATER INSTALLATION**

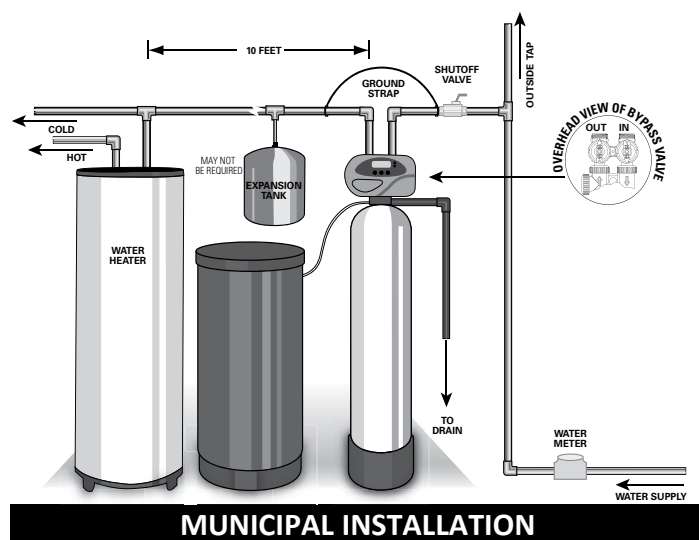

**MUNICIPAL INSTALLATION**

1. The distance between the drain and the water treatment unit should be as short as possible (see #9).
2. Since salt must be added periodically to the brine tank, it should be in an easily accessible location.
3. The media tank should be installed on a firm, level surface (above or below grade).
4. It is NOT recommended to install any water treatment unit with less than 10 feet of piping between its outlet and the inlet of a water heater.



**CAUTION:** To protect the unit in the event of a hot water heater backup, the manufacturer recommends the use of an expansion tank on the outlet side of the unit (see diagram).

5. Do not locate unit where it or its connections (including the drain and overflow lines) will ever be subjected to temperatures under 33°F.
6. Do not subject the tank to any vacuum as this may cause an “implosion” and could result in leaking. If there is a possibility a vacuum could occur, please make provision for a vacuum breaker in the installation.
7. **INLET/OUTLET PLUMBING:** Be sure to install Bypass Valve onto main control valve before beginning plumbing. If it is desired to bypass outside hydrants, a cold water kitchen sink, or other locations, provisions should be made at this time. Install an inlet shutoff valve and plumb to the unit’s bypass valve inlet located at the right rear as you face the unit. There are a variety of installation fittings available. They are listed under the Installation Fitting Assemblies section of the manual. When assembling the installation fitting package (inlet and outlet), connect the fitting to the plumbing system first and then attach the nut, split ring and “O” Ring. Heat from soldering or solvent cements may damage the nut, split ring or “O” Ring. Solder joints should be cool and solvent cements should be set before installing the nut, split ring and “O” Ring. Avoid getting solder flux, primer, and solvent cement on any part of the “O” Rings, split rings, bypass valve or control valve. If the building’s electrical system is grounded to the plumbing, install a copper grounding strap from the inlet to the outlet pipe. Plumbing must be done in accordance with all applicable local codes.

# INSTALLATION

8. **INSTALLING GROUND:** To maintain an electrical ground in metal plumbing of a home's cold water piping (such as a copper plumbing system), install a ground clamp or jumper wiring.

**NOTE:** If replacing an existing unit, also replace the ground clamps/wire. If removing a unit, replace the piping with the same type of piping as the original to assure plumbing integrity and grounding.

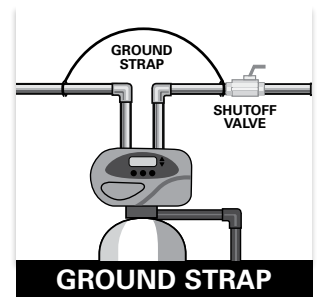

9. **DRAIN LINE:** First, be sure that the drain can handle the backwash rate of the system. Solder joints near the drain must be done prior to connecting the drain line flow control fitting. Leave at least 6" between the drain line flow control fitting and solder joints. Failure to do this could cause interior damage to the flow control. Install a 1/2" I.D. tube to the Drain Line Assembly in accordance with plumbing regulations or discard the tubing nut and use the 3/4" NPT fitting for rigid pipe (recommended). If the backwash rate is greater than 7 gpm, use a 3/4" drain line. Where the drain line is elevated but empties into a drain below the level of the control valve, form a 7" loop at the discharge end of the line so that the bottom of the loop is level with the drain connection on the control valve. This will provide an adequate anti-siphon trap. Piping the drain line overhead <10 ft is normally not a problem. Be sure adequate pressure is available (40-60 psi is recommended). Where the drain empties into an overhead sewer line, a sink-type trap must be used with appropriate air gap (see drawing). Run drain tube to its discharge point in accordance with plumbing codes. Pay special attention to codes for air gaps and anti-siphon devices.



**CAUTION:** Never insert a drain line into a drain, sewer line, or trap. Always allow an air gap of 1-1/2" or twice the pipe diameter, whichever is greater, between the drain line and the wastewater to prevent the possibility of sewage being back-siphoned into the softener.

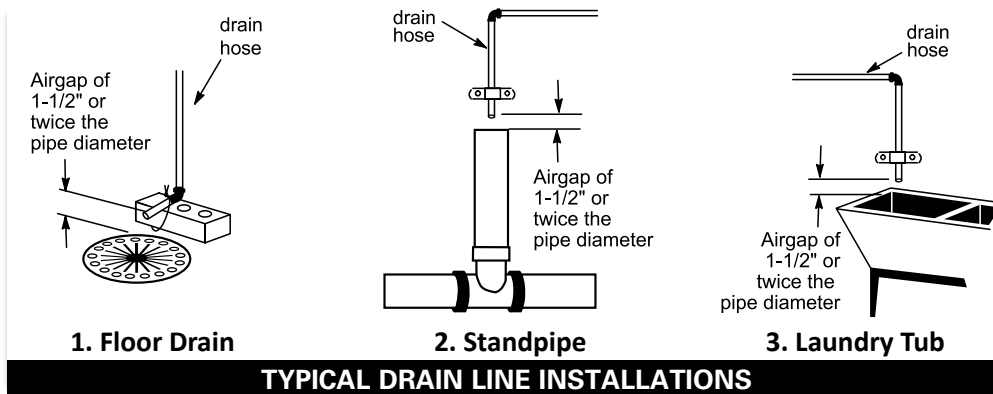

10. **SAFETY BRINE TANK CONNECTION:** Install the 3/8" O.D. polyethylene tube from the Refill Elbow to the Brine Safety Float valve in the brine tank.



Connection at Refill Elbow on the control valve



Connection at Brine Safety Float in brine tank

11. **OVERFLOW LINE CONNECTION:** An overflow drain line is recommended where a brine overflow could damage furnishings or the building structure. Your unit is equipped with a brine tank safety float which greatly reduces the chance of an accidental brine overflow. In the event of a malfunction, however, an overflow line connection will direct the "overflow" to the drain instead of spilling on the floor where it could cause considerable damage. This fitting is an elbow on the side of the brine tank. Attach a length of 1/2" I.D. tubing to fitting and run to drain. Do not elevate overflow line higher than 3" below bottom of overflow fitting. Do not connect this tube into the drain line of the control valve. Overflow line must be a direct, separate line from overflow fitting to drain, sewer, or tub. The overflow line is a gravity drain and cannot run higher than the initial drain point. Allow an air gap as per the drain line instructions.

# PROGRAMMING PROCEDURES

## 1. Set Time of Day

Typically, time of day should only need to be set after extended power outages or when daylight saving time begins or ends or after the battery has been replaced. If an extended power outage occurs, the time of day will flash on and off indicating that the time should be reset. To set the clock:

**STEP 1** – Press the **CLOCK** button.

**STEP 2** – Set the hour of the day using **+** or **-** buttons. AM/PM toggles after 12. Press **NEXT** to go to step 3.

**STEP 3** – Set the minutes using **+** or **-** buttons. Press **NEXT** to go to step 4 or **REGEN** to return to previous step.

**STEP 4** – Set the day of the week using **+** or **-** buttons. Press **NEXT** to exit clock setting or **REGEN** to return to previous step.

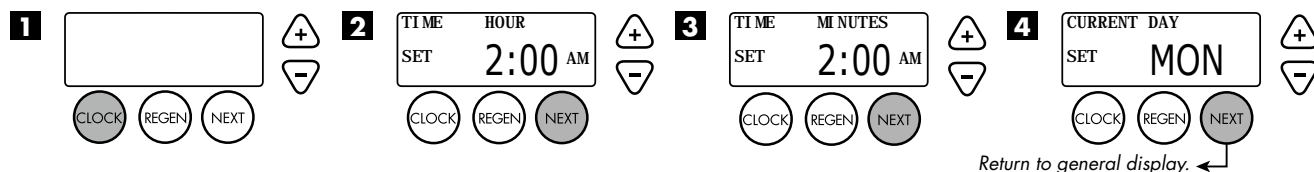

## 2. Programming

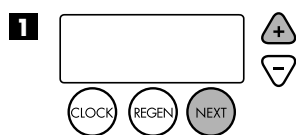

The manufacturer has preset the unit so that the gallons between regenerations will be automatically calculated after the hardness is entered. Press **NEXT** to cycle to the next step or **REGEN** to return to the previous step.

**STEP 1** – Press and hold the **NEXT** and **+** buttons simultaneously for 3 seconds.

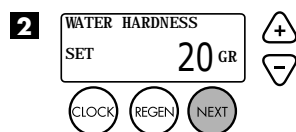

**STEP 2 – HARDNESS:** Use the **+** or **-** buttons to adjust the hardness value in grains per gallons. Adjustable from 1 to 150 gpg in 1 grain increments (default setting is 20).

The hardness value is based on the actual compensated hardness of the water and must be set by an authorized dealer following an on-site water analysis. Adjusting the number will only impact the frequency of regeneration and will not alter or affect the hardness of the water treated by the unit.

**Note:** If a resin media is used, increase the grains per gallon if soluble iron is present (1 ppm = 4 gpg). This screen will not display if “FILTER” mode is selected.

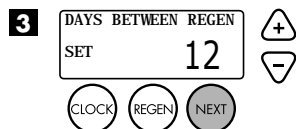

**STEP 3 – DAYS BETWEEN REGENERATION (DAY OVERRIDE):** Use the **+** or **-** buttons to adjust the day override. Adjustable from 1-28 days or OFF. The manufacturer has factory set 12 days as the default.

The Day Override value represents the maximum number of days between regenerations. If any number is set (1-28 days), a regeneration will be scheduled for that day if the gallon capacity has not been met. If OFF is set, the unit will only initiate a regeneration once the gallon capacity has been met.

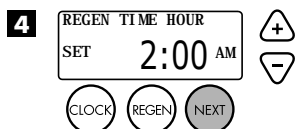

**STEP 4 – REGENERATION HOUR:** Use the **+** or **-** buttons to adjust the time of day the unit will regenerate. AM/PM toggles after 12. The manufacturer has factory set 2:00 A.M. as the default setting which is recommended for a normal household.

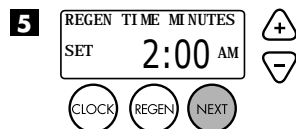

**STEP 5 – REGENERATION MINUTES:** Use the **+** or **-** buttons to set minutes.

**STEP 6 – BACKLIGHT DISPLAY CONTROL:** Use the **+** or **-** buttons to turn the backlight setting ON or OFF. If unit is set to OFF, the backlight will turn off after 5 minutes of inactivity. **This setting is not available on all models.**

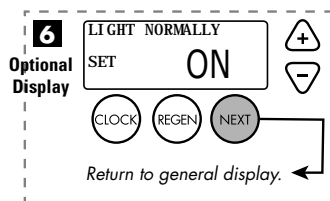

Press **NEXT** to return to General Display.

## FLUSHING OF SYSTEM:

To flush the system of any debris and air after installation is complete, please perform the following steps:

1. Rotate bypass handles to the bypass mode (**Fig. 2 on page 4**).
2. Turn on inlet water and check for leaks in the newly installed plumbing.
3. Fully open a cold water faucet, preferable at a laundry sink or bathtub without an aerator.
4. Wait two to three minutes or until water runs clear, then turn water off and follow start-up instructions.

Below is the name of each cycle as it appears on the screen with a description of the cycle position. The timing of each cycle will vary depending on the unit size as set from the factory.

Name of Cycle	Description
FILL	BRINE TANK FILL
SOFTENING	SOFT WATER BRINE MAKING
BACKWASH	BACKWASH
REGENERANT DRAW DN (DOWN)	BRINE DRAW AND SLOW RINSE
RINSE	FAST RINSE

The system is now ready for filling with water and for testing.

1. With the softener in the bypass mode (**Fig. 2 on page 4**) and the control valve in normal operation where the display shows either the time of day or the gallons remaining, manually add 3" of water to the brine tank.

**NOTE: If too much water is put into the brine tank during softener start up, it could result in a "salty water" complaint after the first regeneration.**

During the first regeneration, the unit will draw out the initial volume of brine/regenerant and refill it with the correct preset amount.

2. With the softener in bypass mode, press and hold the **REGEN** button until the motor starts. Release button. The display reads "FILL" and the remaining time in this step is counting down. Since the brine tank was already filled in Step 1, press **REGEN** again and the display will read SOFTENING 240 (During a full regeneration this will be a 4 hour period for salt to dissolve). Press **REGEN** again to put the valve into "BACKWASH." Once valve has stopped in position, unplug the transformer so that the valve will not cycle to the next position. Open the inlet handle of the bypass valve very slightly allowing water to fill the tank slowly in order to expel air.



**CAUTION: If water flows too rapidly, there will be a loss of media to the drain.**

3. When the water is flowing steadily to the drain without the presence of air, slowly open the inlet valve. Restore power and momentarily press the **REGEN** button to advance the control to the "BRINE" position.
4. With the bypass now in diagnostic mode (**Fig. 3 on page 4**), check to verify that water is being drawn from brine tank with no air leaks or bubbles in the brine line. There should be a slow flow to the drain. Disconnect brine line from the safety float valve in the brine tank and check for a vacuum. After proper confirmation, reconnect brine line making sure to insert properly.
5. Momentarily press **REGEN** again until the display reads "RINSE." There should be a rapid flow to the drain. Unplug transformer to keep the valve in the "RINSE" position. Allow to run until steady, clear and without air. While the unit is rinsing, load the brine tank with water softener salt (**Refer to Brine Tank Maintenance and Salt Section**). Restore power.
6. Place bypass valve in the normal operating mode (**Fig. 1 on page 4**) by opening the outlet bypass handle. Press **REGEN** and the unit will return to the service position with time of day being displayed.

## 7. CONDITIONING OF MEDIA:

**To flush any remaining debris and air from the system again:**

1. Full open a cold water faucet, preferably at a laundry sink or bathtub without an aerator.
2. Wait two to three minutes or until water runs clear, then turn water off.
3. Turn on hot water and check for air, then turn water off after air is discharged.

## 8. SANITIZING OF UNIT UPON INSTALLATION AND AFTER SERVICE:

**At this time, it is advised to sanitize the softener:**

1. Open brine tank and remove brine well cover.
2. Pour 1 oz. of household bleach into the brine well.

**NOTE: Avoid pouring bleach directly onto the safety float components in the brine well.**

3. Replace brine well cover.

Unit sanitizing will be complete when the first cycle is run and the bleach is flushed from the unit.

9. Check time of day. Start-up is now complete.



# OPERATING DISPLAYS AND MAINTENANCE:

**1. GENERAL OPERATION:** When the system is operating, one of five displays may be shown and will alternate with the installing dealer's name and phone number for future service (if set). Pressing **NEXT** will alternate between the displays.

1. **Time of Day Screen:** Displays the current time of day, the day of the week, and flow rate.
2. **Flow Rate Screen:** Displays the current treated water flow rate through the system in Gallons Per Minute.
3. **Capacity Remaining Screen:** Displays the amount of gallons of treated water remaining until the system triggers a regeneration.
4. **Days to a Regen Screen:** Displays the number of days until the system triggers a regeneration. Based on the days override value.
5. **Dealer Name Screen:** Displays dealer specific name and phone number. This scrolling display will only appear if set by the dealer.

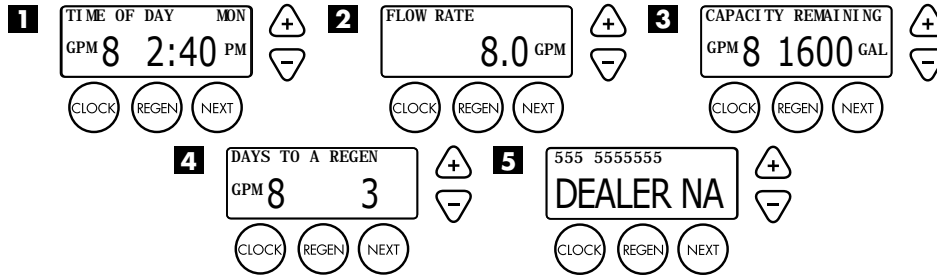

If the system has called for a regeneration that will occur at the preset time of regeneration, the words "REGEN TODAY" will appear on the display. If a water meter is installed, "GPM" flashes on the display when water is being treated, indicating gallons per minute flowing through the system.

**2. REGENERATION MODE:** Typically, a system is set to regenerate at a time of no water usage. If there is a demand for water when the system is regenerating, untreated water will be delivered. When the system begins to regenerate, the display will include information about the step of the regeneration process and the time remaining for that step to be completed. The system runs through the steps automatically and will reset itself to provide treated water when the regeneration has been completed.

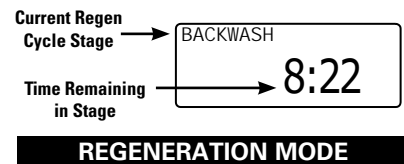

**3. MANUAL REGENERATION:** Sometimes there may be a need to regenerate a unit before the control valve calls for it. This may be needed if a period of heavy water use is anticipated or when the system has been operating without salt.

- To initiate a manual regeneration at the next preset regeneration time, press and release the **REGEN** button. The words "REGEN TODAY" will flash on the display to indicate that the system will regenerate at the scheduled regeneration time (see the Programming Procedures section). If you pressed the **REGEN** button in error, pressing and releasing the button again will cancel the command.
- To initiate a manual regeneration immediately, press and hold the **REGEN** button for three seconds. The system will begin to regenerate immediately. **This command cannot be canceled.**

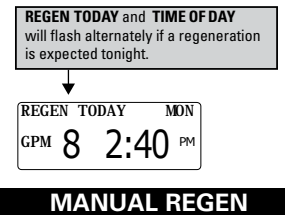

Once a manual regeneration is initiated, the unit will enter the FILL position. This position allows water to enter the brine tank until it reaches the proper level. Once this position is complete, you will notice a 240 minute (4 hours) SOFTENING position. This 4 hour window allows the salt to dissolve and achieve proper brine strength. During these FILL and SOFTENING positions, you will have softened water available for use. Once the unit advances to the BACKWASH position and subsequent positions thereafter (see Start Up Instructions for regeneration sequence), the unit will deliver water, but it will be untreated.

**IMPORTANT:** With the Dry Salt Storage Feature, the brine tank will refill 4 hours before the actual regeneration occurs. You may experience a small amount of noise for a short period of time at 10:00 p.m. (with factory settings) on the night that the regeneration is to occur. This noise is only the brine tank filling and at no time during this process will you be without treated water.

# OPERATING DISPLAYS AND MAINTENANCE:

**4. POWER LOSS AND BATTERY REPLACEMENT:** If an extended power outage occurs, the control valve will retain the time of day settings until the board's battery is depleted. Once the battery is depleted, the display will appear dark and absent of any information. If this occurs, following these steps will determine if the problem is a low battery or a board failure.

To determine if the battery is depleted:

1. Remove valve cover. Disconnect power from PC Board at the four pin connector at the bottom of the board.
2. Wait five minutes for board to de-energize. Remove battery with a non-conductive/non-metallic material. Reference the Parts Breakdown section of this manual for location.
3. Wait five minutes for board to de-energize.
4. With the battery out, re-connect the power supply to the board. The board's display should begin to show information.

**This indicates that the board is operating correctly. If the display does not work, call installing dealer for service.**

5. To replace with new battery, unplug transformer from outlet. Install a 3 volt Lithium Coin Cell type 2032 battery, available at most stores. Plug unit back into outlet.

**It is important to replace the battery with the valve unplugged to avoid causing a short and potentially ruining the board.**

6. Reset the time of day (see programming procedures) and initiate regeneration (see operating displays and maintenance).

**If these procedures do not remedy the problem, please consult the installing dealer for service.**

**5. ERROR MESSAGE:** If the word "ERROR" appears and flashes alternately with the dealer name and phone number, record the ERROR number and contact your servicing dealer promptly. This indicates that the control valve was not able to function properly.

**6. BRINE TANK MAINTENANCE AND SALT:** Refill the brine tank as necessary, making sure at least 1/3 of the brine tank is full at all times. Without proper salt levels, the water softener may not operate properly.

Because "typical" settings of this water softener include a dry salt storage feature (a small amount of water in brine tank between regeneration), the manufacturer recommends the use of solar salt for best results. The brine tank is manufactured for the use of solar, pellets or rock salt. **Do not use block salt.** If pellet or rock salt is used, a cleaning of the brine tank every six months is recommended. If the dry salt storage feature is not being utilized, block salt may be used.



**Caution:** With some models the manufacturer does NOT recommend the use of any resin cleaners, nor placing any resin cleaners into the brine tank. Furthermore, do not use any salt that indicates it is an iron cleaning salt or that contains any cleaning additives. This may be harmful to the water softener and for human consumption. Consult dealer for proper cleaning instructions.

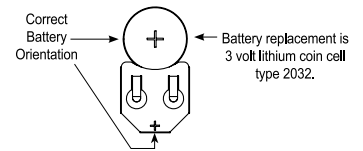

When replacing the battery, align positives and push down to fully seat.

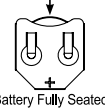

## BATTERY REPLACEMENT



## ERROR SCREEN



## SALT ALARM SCREEN

# TROUBLESHOOTING GUIDE

PROBLEM	CAUSE	CORRECTION
<b>1. No display on PC board.</b>	A. Depleted battery.	A. See Operating Display and Maintenance section.
	B. Control valve power adapter not plugged into outlet or power cord end not connected to PC board connection.	B. Plug power adapter into outlet or connect power cord end to PC board connection.
	C. Improper power supply.	C. Verify proper voltage is being delivered to PC board.
	D. Defective power adapter.	D. Replace power adapter.
	E. Defective PC board.	E. Replace PC board.
	F. No power at electric outlet.	F. Repair outlet or use working outlet.
<b>2. PC board does not display correct time of day.</b>	A. Power adapter plugged into electric outlet controlled by light switch.	A. Use uninterrupted outlet.
	B. Tripped breaker switch and/or tripped GFI.	B. Reset breaker switch and/or GFI switch.
	C. Power outage.	C. Reset time of day. If PC board has battery back up present the battery may be depleted. See front cover and drive assembly drawing for instructions.
	D. Defective PC board.	D. Replace PC board.
<b>3. Display does not indicate that water is flowing. Refer to user instructions for how the display indicates water is flowing.</b>	A. Bypass valve in bypass position.	A. Turn bypass handles to place bypass in service position.
	B. Meter is not connected to meter connection on PC board.	B. Connect meter to three pin connection labeled METER on PC board.
	C. Restricted/stalled meter turbine.	C. Remove meter and check for rotation or foreign material.
	D. Meter wire not installed securely into three pin connector.	D. Verify meter cable wires are installed securely into three pin connector labeled METER.
	E. Defective meter.	E. Replace meter.
	F. Defective PC board.	F. Replace PC board.
<b>4. Control valve regenerates at wrong time of day.</b>	A. Power outage.	A. Reset time of day. If PC board has battery back up present the battery may be depleted. See front cover and drive assembly drawing for instructions.
	B. Time of day not set correctly.	B. Reset to correct time of day.
	C. Time of regeneration set incorrectly.	C. Reset regeneration time.
	D. Control valve set at immediate regeneration.	D. Check programming setting and reset to DELAYED (for a delayed regen time).
<b>5. Time of day flashes on and off.</b>	A. Power outage.	A. Reset time of day. If PC board has battery back up present the battery may be depleted. See front cover and drive assembly drawing for instructions.
<b>6. Control valve does not regenerate automatically when the correct button(s) is pressed and held. For timeclock valves the buttons are + or -. For all other valves the button is REGEN.</b>	A. Broken drive gear or drive cap assembly.	A. Replace drive gear or drive cap assembly.
	B. Broken piston rod.	B. Replace piston rod.
	C. Defective PC board.	C. Defective PC board.
	D. Cover installed incorrectly.	D. Reinstall cover.

# TROUBLESHOOTING GUIDE

PROBLEM	CAUSE	CORRECTION
<b>7. Control valve does not regenerate automatically but does when the correct button(s) is depressed and held. For timeclock valves the buttons are + or -. For all other valves the button is REGEN.</b>	A. Bypass valve in bypass position.	A. Turn bypass handles to place bypass in service position.
	B. Meter is not connected to meter connection on PC board.	B. Connect meter to three pin connection labeled METER on PC board.
	C. Restricted/stalled meter turbine.	C. Remove meter and check for rotation or foreign material.
	D. Incorrect programming.	D. Check for programming error.
	E. Meter wire not installed securely into three pin connector.	E. Verify meter cable wires are installed securely into three pin connector labeled METER.
	F. Defective meter.	F. Replace meter.
	G. Defective PC board.	G. Replace PC board.
<b>8. Hard or untreated water is being delivered.</b>	A. Bypass valve is open or faulty.	A. Fully close bypass valve or replace.
	B. Media is exhausted due to high water usage.	B. Check program settings or diagnostics for abnormal water usage.
	C. Meter not registering.	C. Remove meter and check for rotation or foreign material.
	D. Water quality fluctuation.	D. Test water and adjust program values accordingly.
	E. No regenerant or low level of regenerant in regenerant tank.	E. Add proper regenerant to tank.
	F. Control fails to draw in regenerant.	F. Refer to Troubleshooting Guide number 12.
	G. Insufficient regenerant level in regenerant tank.	G. Check refill setting in programming. Check refill flow control for restrictions or debris and, if necessary, replace.
	H. Damaged seal/stack assembly/piston.	H. Replace seal/stack assembly and/or piston.
	I. Control valve body type and piston type mix matched.	I. Verify proper control valve body type and piston type match.
	J. Fouled media bed.	J. Replace media bed.
<b>9. Control valve uses too much regenerant.</b>	A. Improper refill setting.	A. Check refill setting.
	B. Improper program settings.	B. Check program setting to make sure they are specific to the water quality and application needs.
	C. Control valve regenerates frequently.	C. Check for leaking fixtures that may be exhausting capacity or system is undersized.
<b>10. Residual regenerant being delivered to service.</b>	A. Low water pressure.	A. Check incoming water pressure – water pressure must remain at minimum of 25 psi.
	B. Incorrect, damaged, or restricted injector.	B. Replace injector with correct size for the application.
	C. Restricted drain line.	C. Check drain line for restrictions or debris and remove any obstructions.
<b>11. Excessive water in regenerant tank.</b>	A. Improper program settings.	A. Check refill setting.
	B. Plugged injector.	B. Remove injector and replace.
	C. Drive cap assembly not tightened in properly.	C. Re-tighten the drive cap assembly.
	D. Damaged seal/stack assembly/piston.	D. Replace seal/stack assembly and/or piston.
	E. Restricted or kinked drain line.	E. Check drain line for restrictions or debris and or unkink drain line.
	F. Plugged backwash flow controller.	F. Remove backwash flow controller and replace, if necessary.
	G. Missing refill flow controller.	G. Install refill flow controller.
	H. Brine tube not inserted properly into brine elbow in brine tank.	H. Install tube all the way into elbow.

# TROUBLESHOOTING GUIDE

PROBLEM	CAUSE	CORRECTION
<b>12. Control valve fails to draw in regenerant.</b>	A. Injector is plugged.	A. Remove injector and replace.
	B. Faulty regenerant piston.	B. Replace regenerant piston.
	C. Regenerant line connection leak.	C. Inspect regenerant line for air leak.
	D. Drain line restriction or debris cause excess back pressure.	D. Inspect drain line and remove to correct restriction.
	E. Drain line too long or too high.	E. Shorten length and or height.
	F. Low water pressure.	F. Check incoming water pressure – water pressure must remain at minimum of 25 psi.
<b>13. Water running to drain.</b>	A. Power outage during regeneration.	A. Upon power being restored control will finish the remaining regeneration time. Reset time of day. If PC board has battery back up present the battery may be depleted. See front cover and drive assembly drawing for instructions.
	B. Damaged seal/stack assembly.	B. Replace seal/stack assembly.
	C. Piston assembly failure.	C. Replace piston assembly.
	D. Drive cap assembly not tightened in properly.	D. Re-tighten the drive cap assembly.
<b>14. E1, Err – 1001, Err – 101 = Control unable to sense motor movement.</b>	A. Motor not inserted full to engage pinion, motor wires broken or disconnected.	A. Disconnect power, make sure motor is fully engaged, check for broken wires, make sure two pin connector on motor is connected to the two pin connection on the PC board labeled MOTOR. Press NEXT and REGEN buttons for 3 seconds to resynchronize software with piston position or disconnect power supply from PC board for 5 seconds and then reconnect.
	B. PC board not properly snapped into drive bracket.	B. Properly snap PC board into drive bracket and then Press NEXT and REGEN buttons for 3 seconds to resynchronize software with piston position or disconnect power supply from PC board for 5 seconds and then reconnect.
	C. Missing drive gears.	C. Replace missing gears.
	D. Motor does not drive/run.	D. Replace motor.
	E. Viewing eye or encoder is blocked or damaged.	E. clear viewing eye on board, on drive bracket, or replace PC board if no debris is found.
<b>15. E2, Err – 1002, Err – 102 = Excessive Motor Draw.</b>	A. Foreign material is lodged in control valve.	A. Open up control valve and pull out piston assembly and seal/stack assembly for inspection. Press NEXT and REGEN buttons for 3 seconds to resynchronize software with piston position or disconnect power supply from PC board for 5 seconds and then reconnect.
	B. Mechanical binding.	B. Check piston and seal/stack assembly, check reduction gears, check drive bracket and main drive gear interface. Press NEXT and REGEN buttons for 3 seconds to resynchronize software with piston position or disconnect power supply from PC board for 5 seconds and then reconnect.
	C. Drive cap too loose.	C. Completely tighten drive cap assembly.
	D. Drive cap not “clicked” into backplate.	D. Verify that backplate is properly “clicked” into place.

# TROUBLESHOOTING GUIDE

PROBLEM	CAUSE	CORRECTION
<b>16. E3, Err – 1003, Err – 103 = Control valve motor ran too long and was unable to find the next cycle position.</b>	A. Drive bracket not snapped in properly and out enough that reduction gears and drive gear do not interface.	A. Snap drive bracket in properly then Press NEXT and REGEN buttons for 3 seconds to resynchronize software with piston position or disconnect power supply from PC board for 5 seconds and then reconnect.
<b>17. E4, Err – 1004, Err – 104 = Control valve motor ran too long and timed out trying to reach home position.</b>	A. Drive bracket not snapped in properly and out enough that reduction gears and drive gear do not interface.	A. Snap drive bracket in properly then Press NEXT and REGEN buttons for 3 seconds to resynchronize software with piston position or disconnect power supply from PC board for 5 seconds and then reconnect.
	B. Piston not connected to drive cap.	B. Connect or replace (if damaged) piston/drive cap.
<b>18. Err – 1006, Err – 106, Err – 116 = MAV/ SEPS/ NHBP/ AUX MAV valve motor ran too long and unable to find the proper park position.</b> <ul style="list-style-type: none"> <li>● Motorized Alternating Valve = MAV</li> <li>● Separate Source = SEPS</li> <li>● No Hard Water Bypass = NHBP</li> <li>● Auxiliary MAV = AUX MAV</li> </ul>	A. Control valve programmed for ALT A or B, nHbP, SEPS, or AUX MAV with out having a MAV or NHBP valve attached to operate that function.	A. Press NEXT and REGEN buttons for 3 seconds to resynchronize software with piston position or disconnect power supply from PC board for 5 seconds and then reconnect. Then reprogram valve to proper setting.
	B. MAV/NHBP motor wire not connected to PC board.	B. Connect MAV/NHBP motor to PC board two pin connection labeled DRIVE. Press NEXT and REGEN buttons for 3 seconds to resynchronize software with piston position or disconnect power supply from PC board for 5 seconds and then reconnect.
	C. MAV/NHBP motor not fully engaged with reduction gears.	C. Properly insert motor into casing, do not force into casing Press NEXT and REGEN buttons for 3 seconds to resynchronize software with piston position or disconnect power supply from PC board for 5 seconds and then reconnect.
	D. Foreign matter built up on piston and stack assemblies creating friction and drag enough to time out motor.	D. Replace piston and stack assemblies. Press NEXT and REGEN buttons for 3 seconds to resynchronize software with piston position or disconnect power supply from PC board for 5 seconds and then reconnect.
<b>19. Err – 1007, Err – 107, Err – 117 = MAV/ SEPS/NHBP/ AUX MAV valve motor ran too short (stalled) while looking for proper park position.</b> <ul style="list-style-type: none"> <li>● Motorized Alternating Valve = MAV</li> <li>● Separate Source = SEPS</li> <li>● No Hard Water Bypass = NHBP</li> <li>● Auxiliary MAV = AUX MAV</li> </ul>	A. Foreign material is lodged in MAV/NHBP valve.	A. Open up MAV/NHBP valve and check piston and seal/ stack assembly for foreign material. Press NEXT and REGEN buttons for 3 seconds to resynchronize software with piston position or disconnect power supply from PC board for 5 seconds and then reconnect.
	B. Mechanical binding.	B. Check piston and seal/stack assembly, check reduction gears, drive gear interface, and check MAV/NHBP black drive pinion on motor for being jammed into motor body. Press NEXT and REGEN buttons for 3 seconds to resynchronize software with piston position or disconnect power supply from PC board for 5 seconds and then reconnect.

# TROUBLESHOOTING GUIDE

PROBLEM	CAUSE	CORRECTION
<b>20. Err – 201</b> 200 errors are only viewable in history screens. These do not flash when error occurs.	A. Invalid regeneration cycle step detected.	A. Replace PC board.
<b>21. Err – 202</b> 200 errors are only viewable in history screens. These do not flash when error occurs.	A. Short power disruption.	A. Check transformer voltage and verify power source.
	B. Foreign material dislodged.	B. Check piston and stack for damage.
<b>22. Err – 204 = Leak detected</b> 200 errors are only viewable in history screens. These do not flash when error occurs.	A. Occurs when dP input is active for “ALARM” and the input is closed. The alarm buzzer will activate and the screen will display the error.	A. Check for low flow leak. Press NEXT and REGEN buttons for 3 seconds to resynchronize software with piston position or disconnect power supply from PC Board for 5 seconds and then reconnect to clear error.
<b>23. Err – 400*</b> <b>Memory Errors</b> *All 400 errors pertain to memory related errors. 400 and 200 errors are only viewable in history screens. These do not flash when error occurs.	A. Depleted Battery.	A. See Operating Display and Maintenance section.
	B. Defective PC Board.	B. Replace PC board.

# REPLACEMENT PARTS:

## FRONT COVER AND DRIVE ASSEMBLY

Item #	Legacy Part #	Current Part #	Description	Qty.
1	CV3367-01-A	100246343	Evolve Black cover assembly	1
	CV3367-01WR-A	100246345	Evolve Gray cover assembly	1
2	CV3107-1	100246273	Motor Assembly	1
3	CV3002-A	100246193	Drive assembly (includes #5 and #6)	—
4	CV4229XP-03	100243791	PC Board, Evolve ES	1
5	CV3110	100246279	Drive gear, 12 x 36	3
6	CV3109	100246278	Drive gear cover	1
not shown	CV3186-06	100249863	Transformer, 110V-12V (standard)	1
	CV3684-WR-GLD	100244240	Optional weather cover	1

**NOTE: Battery Location**

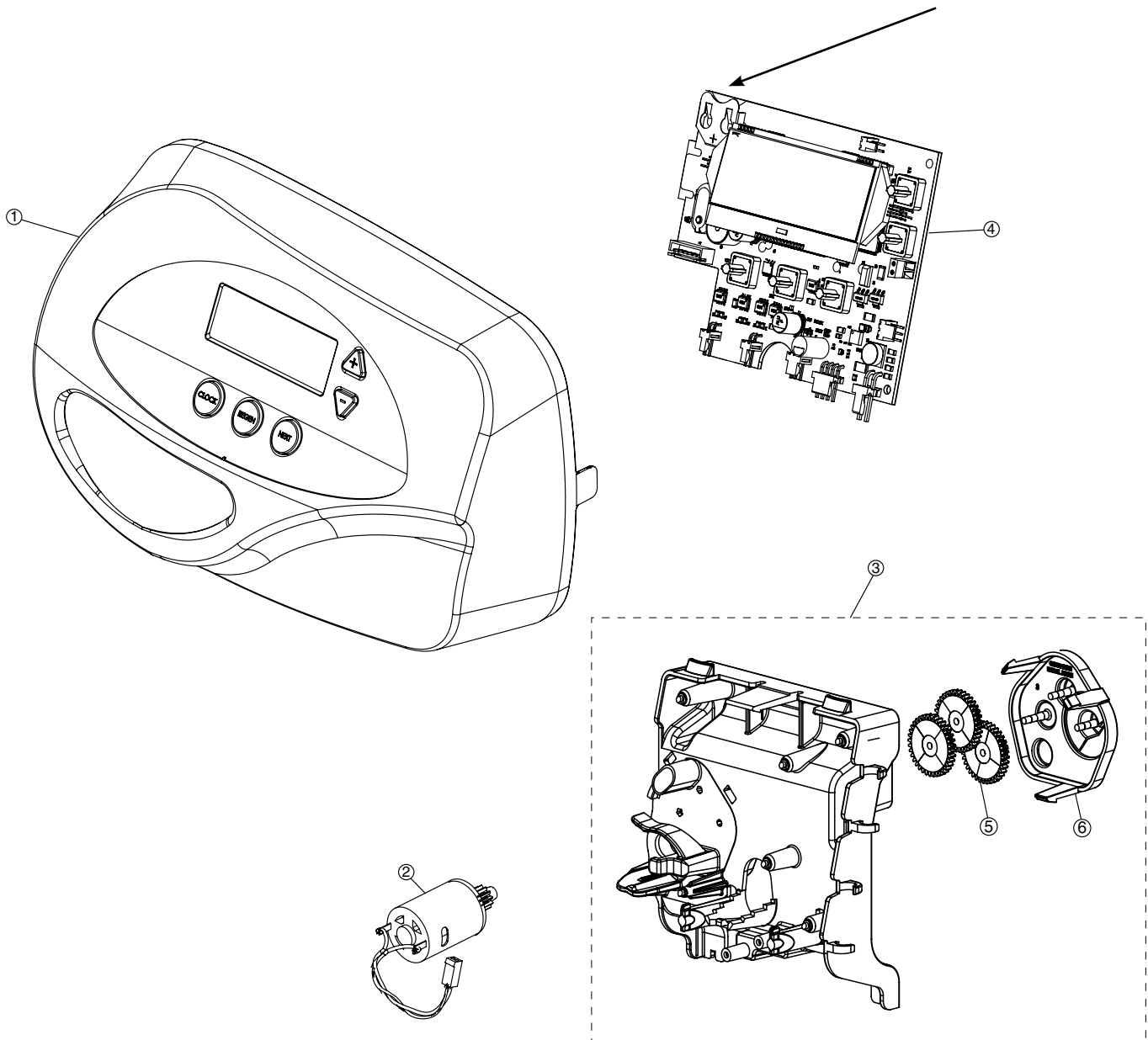



# REPLACEMENT PARTS:

## PISTON ASSEMBLY

Item #	Legacy Part #	Current Part #	Description	Qty.
1	CV3005-02	100249844	1" spacer stack assembly	1
	CV3430-01	100249865	1.25" spacer stack assembly	1
2	CV3004	100246196	Drive cap assembly	1
3	CV3135	100246281	O-ring 228 (drive cap o-ring)	1
4	CV3011	100246232	1" piston assembly downflow	1
	CV3011-01	100246233	1" piston assembly upflow	1
	CV3407	100243924	1.25" piston assembly downflow	1
5	CV3174	100246296	Regenerant piston	1
6	CV3001-04	100244557	1" body assembly downflow	1
	CV3001-04UP	100243827	1" body assembly upflow	1
	CV3020	100246239	1.25" body assembly downflow	1
7	CV3368	100246346	Drive backplate	1
not shown	CD1225-05	100249834	Top basket softener (optional)	1

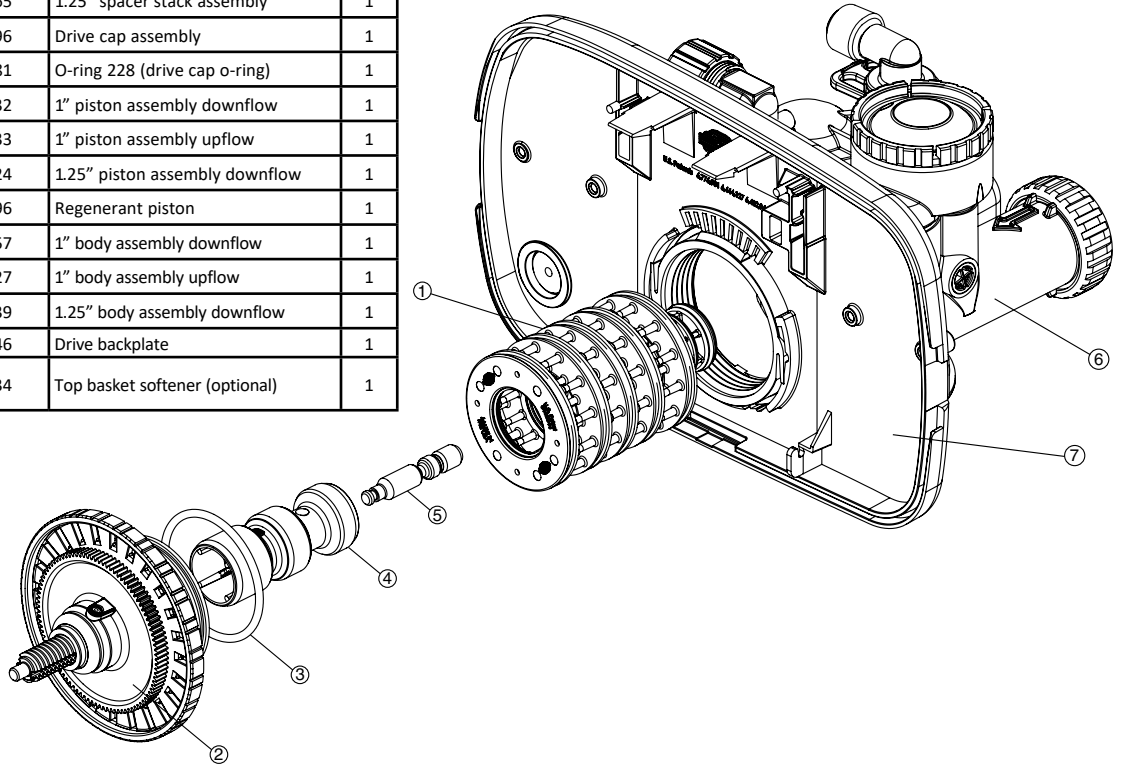

## TANK O-RINGS

Item #	Legacy Part #	Current Part #	Description	Qty.
1	CV3180	100246307	Base O-Ring	1
2	CV3105	100246272	O-Ring 215	1
	CV3358	100246341	O-Ring 219 (for 1.25" distributor tubes)	1

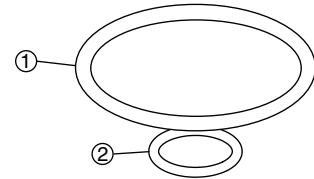

# REPLACEMENT PARTS

## BYPASS VALVE

Item #	Legacy Part #	Current Part #	Description	Qty.
1	CV3006	100249845	Bypass assembly	1
2	CV3147	100246284	Bypass handles	2

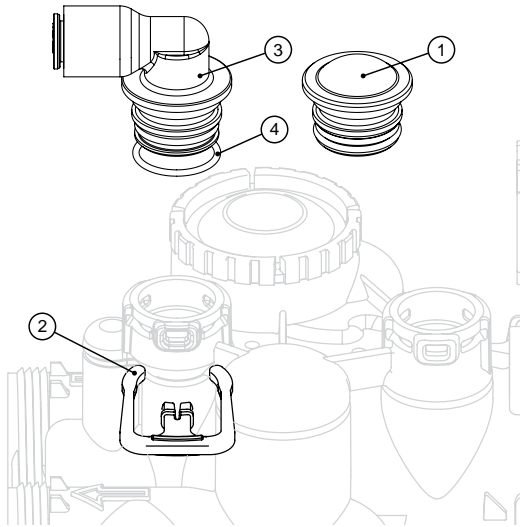
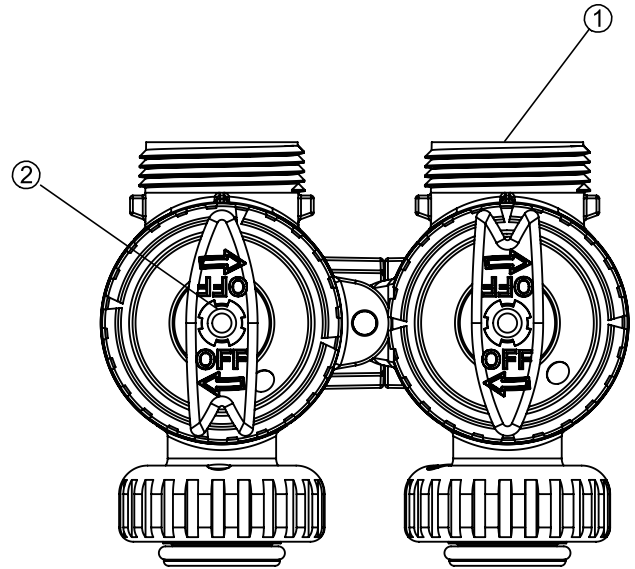

## REFILL PORT ASSEMBLY

Item #	Legacy Part #	Current Part #	Description	Qty.
1	CV3195-01	100246323	Refill port plug assembly	1
2	CH4615	100245862	Elbow locking clip	1
3	CV4144	100245015	3/8" Elbow, Parker fitting	1
4	CV3163	100246291	O-ring 019	1

## SERVICE WRENCH - 100249864 (CV3193-02)

Although no tools are necessary to assemble or disassemble the valve, the Service Wrench, (shown in various positions on the valve) is available to aid in assembly or disassembly.

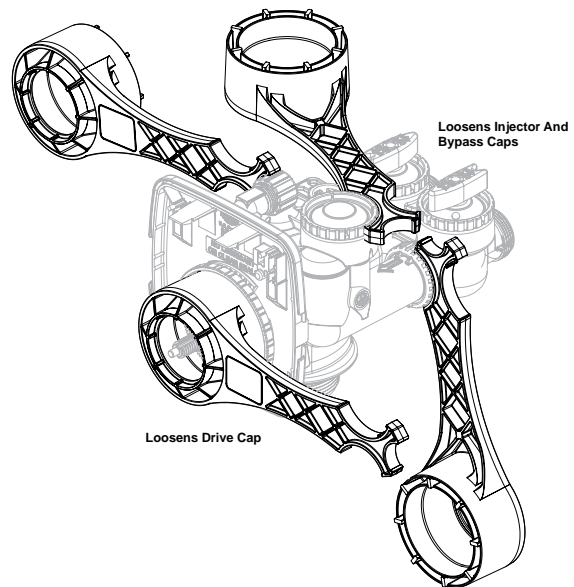

# REPLACEMENT PARTS

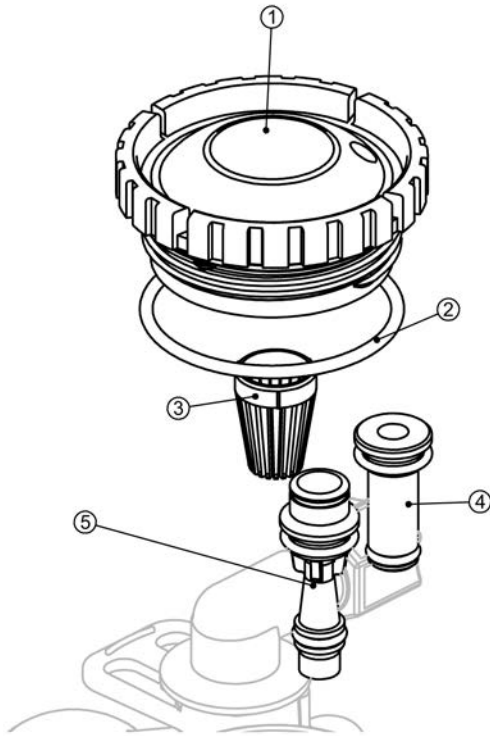

## INJECTOR ASSEMBLIES

Item #	Legacy Part #	Current Part #	Description	Qty.
1	CV3176	100246304	Injector cap	1
2	CV3152	100244507	O-ring 135	1
3	CV3177-01	100246305	Injector screen	1
4	CV3010-1Z	100246221	Injector assembly plug	1
5	CV3010-1A	100246211	A injector assembly, <b>BLACK</b>	1
	CV3010-1B	100246212	B injector assembly, <b>BROWN</b>	
	CV3010-1C	100246213	C injector assembly, <b>VIOLET</b>	
	CV3010-1D	100249849	D injector assembly, <b>RED</b>	
	CV3010-1E	100246214	E injector assembly, <b>WHITE</b>	
	CV3010-1F	100246215	F injector assembly, <b>BLUE</b>	
	CV3010-1G	100246216	G injector assembly, <b>YELLOW</b>	
	CV3010-1H	100246217	H injector assembly, <b>GREEN</b>	
	CV3010-1I	100246218	I injector assembly, <b>ORANGE</b>	
	CV3010-1J	100246219	J injector assembly, <b>LIGHT BLUE</b>	
	CV3010-1K	100246220	K injector assembly, <b>LIGHT GREEN</b>	

\*The injector plug and the injector each use one lower and one upper o-ring

## WATER METER AND METER PLUG

Item #	Legacy Part #	Current Part #	Description	Qty.
1	CV3151	100246287	Nut, 1" Quick Connect	1
2	CV3003	100253284	Meter assembly	1
3	CV3003-01	100246195	Meter plug assembly	1

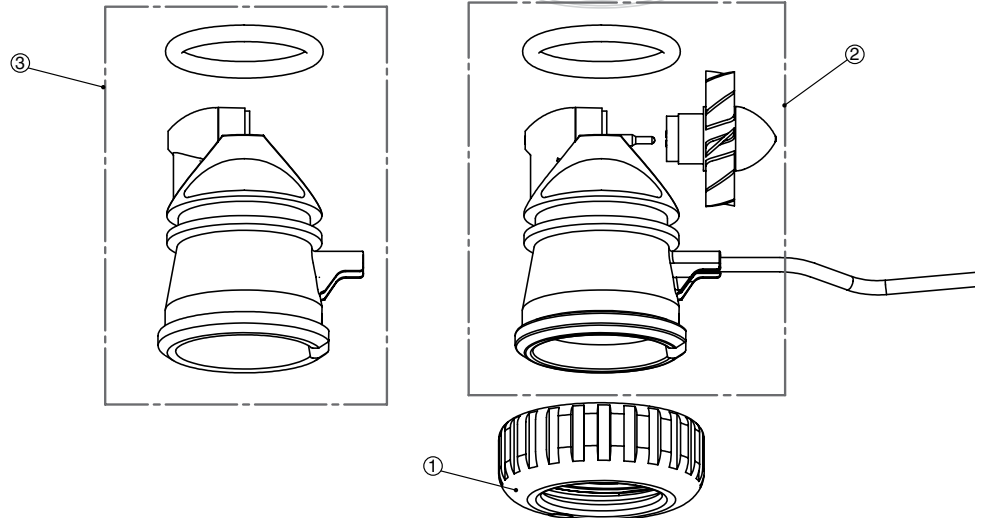

# REPLACEMENT PARTS

## DRAIN LINE ASSEMBLY 3/4"

Item #	Legacy Part #	Current Part #	Description	Qty.
1	CH4615	100245862	Elbow locking clip	1
2	CPKP10TS8-BULK	100245919	Optional insert, 5/8" tube	1
3	CV3192	100246322	Optional nut, 3/4" drain elbow	1
4	CV3158-02	100249851	Drain elbow, 3/4" NPT with O-ring (w/o silencer)	1
5	CV3163	100246291	O-ring 019	1
6	CV3159-01	100246290	DLFC retainer assembly	1
7	CV3162-007	100244908	0.7 DLFC for 3/4" elbow	1
	CV3162-010	100244909	1.0 DLFC for 3/4" elbow	
	CV3162-013	100244910	1.3 DLFC for 3/4" elbow	
	CV3162-017	100244911	1.7 DLFC for 3/4" elbow	
	CV3162-022	100249852	2.2 DLFC for 3/4" elbow	
	CV3162-027	100249853	2.7 DLFC for 3/4" elbow	
	CV3162-032	100249854	3.2 DLFC for 3/4" elbow	
	CV3162-042	100249855	4.2 DLFC for 3/4" elbow	
	CV3162-053	100249856	5.3 DLFC for 3/4" elbow	
7	CV3162-065	100249857	6.5 DLFC for 3/4" elbow	1
	CV3162-075	100249858	7.5 DLFC for 3/4" elbow	
	CV3331A	100245051	Drain elbow and retainer assembly (requires DLFC)	

Items 2 and 3, nut and insert are only used with 1/2" I.D. by 5/8" O.D. polytubing. For other piping material, the 3/4" NPT is used.

## DRAIN LINE ASSEMBLY 1"

Item #	Legacy Part #	Current Part #	Description	Qty.
1	CH4615	100245862	Elbow locking clip	1
2	CV3166	100246292	Drain FTG body 1	1
	CV3166-01	100246293	FTG flow control body 1	
3	CV3163	100246291	O-ring 019	1
4	CV3150	100246286	Split ring	1
5	CV3151	100246287	Nut 1" QC	1
6	CV3105	100246272	O-ring 215	1
7	CV3190-090	100246313	9.0 gpm DLFC for 1" elbow	One DLFC must be used if 1" fitting is used
	CV3190-100	100246314	10.0 gpm DLFC for 1" elbow	
	CV3190-110	100246315	11.0 gpm DLFC for 1" elbow	
	CV3190-130	100246316	13.0 gpm DLFC for 1" elbow	
	CV3190-150	100246317	15.0 gpm DLFC for 1" elbow	
	CV3190-170	100246318	17.0 gpm DLFC for 1" elbow	
	CV3190-200	100246319	20.0 gpm DLFC for 1" elbow	
	CV3190-250	100246320	25.0 gpm DLFC for 1" elbow	
8	CV3008-04	100243824	FTG Drain 1" Strt No/Silencer (requires DLFC)	1

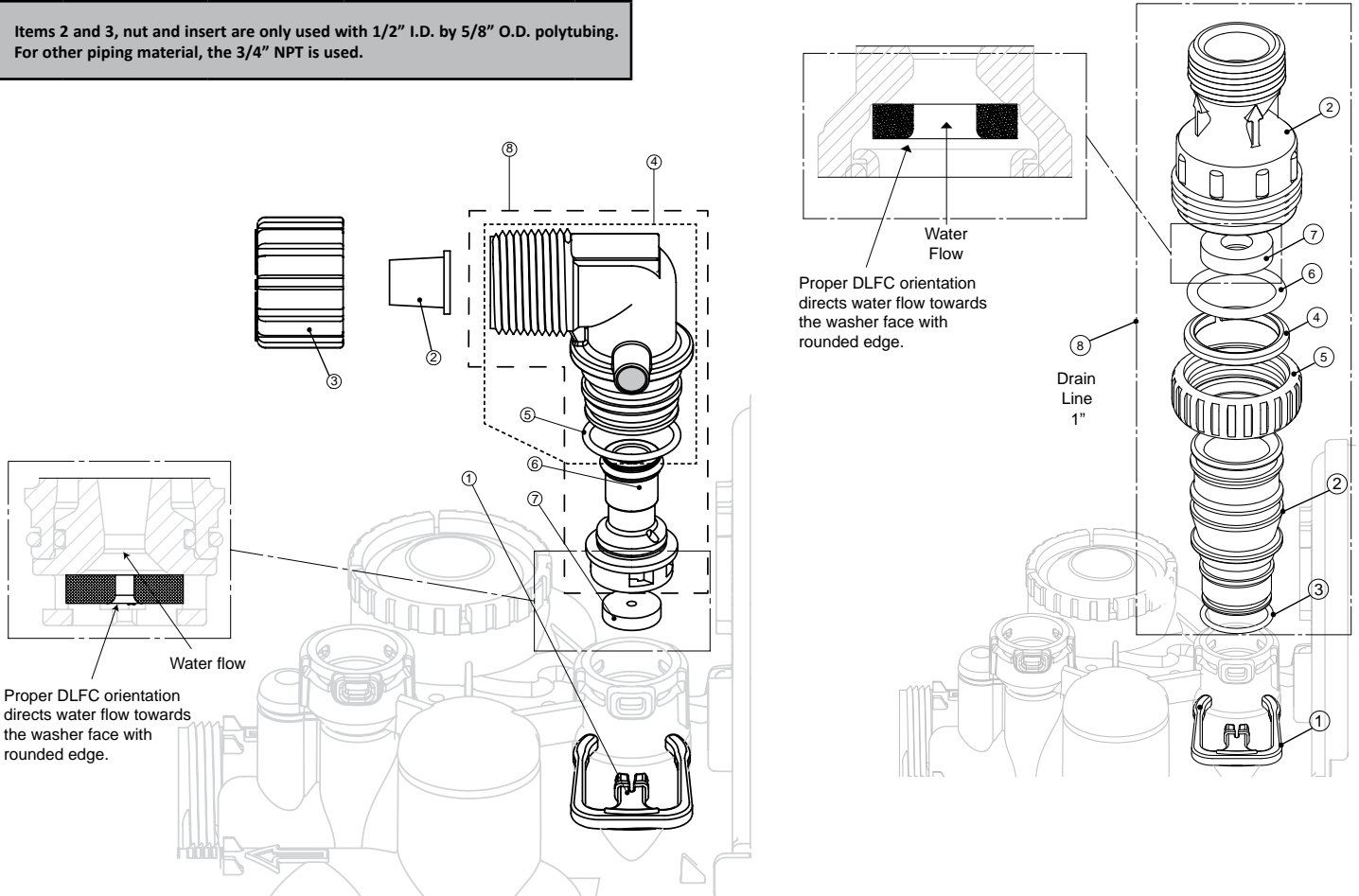

# REPLACEMENT PARTS

## BRINE TANK ASSEMBLY (EV)

Item #	Legacy Part #	Current Part #	Description	Qty.
1	CG2191-92	100245811	Brine tank cover, injection molded EV	1
2	CH1095-01	100245856	Optional 18" diameter salt grid	1
	CH1080	100245853	Optional 24" diameter salt grid (Does not include 1 1/2" PVC riser legs)	1
3	BT1833-1A	100245568	18" x 33" brine tank assembly	1
	BT1840-1A	100245574	18" x 40" brine tank assembly	1
	BT2441-1A	100245576	24" x 41" brine tank assembly	1
4	CH1030-29S	100245837	4" x 29" slotted brine well (18 x 33 BT)	1
	CH1030-36S	100245841	4" x 36" slotted brine well (18 x 40, 24 x 40 BTs)	1
5	CH1018	100245836	2 piece overflow set	1
6	CH4500-48	100245857	474 air check assembly, 1/2" x 48"	1
7	CH4600-50	100245860	474 safety brine valve w/ .5 gpm flow control	1
8	CH7016	100245880	Cap 4" brine well	1
9	CH4626	100245864	Nut safety brine valve stand off	1
<b>Assemblies</b>				
10	CH4700-29WR-1	100244899	.5 gpm safety float assembly, 18" x 33"	
	CH4700-36.5WR-1	100245872	.5 gpm safety float assembly, 18" x 40"	

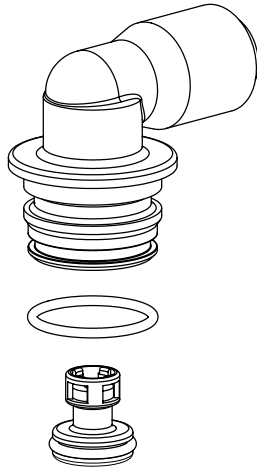
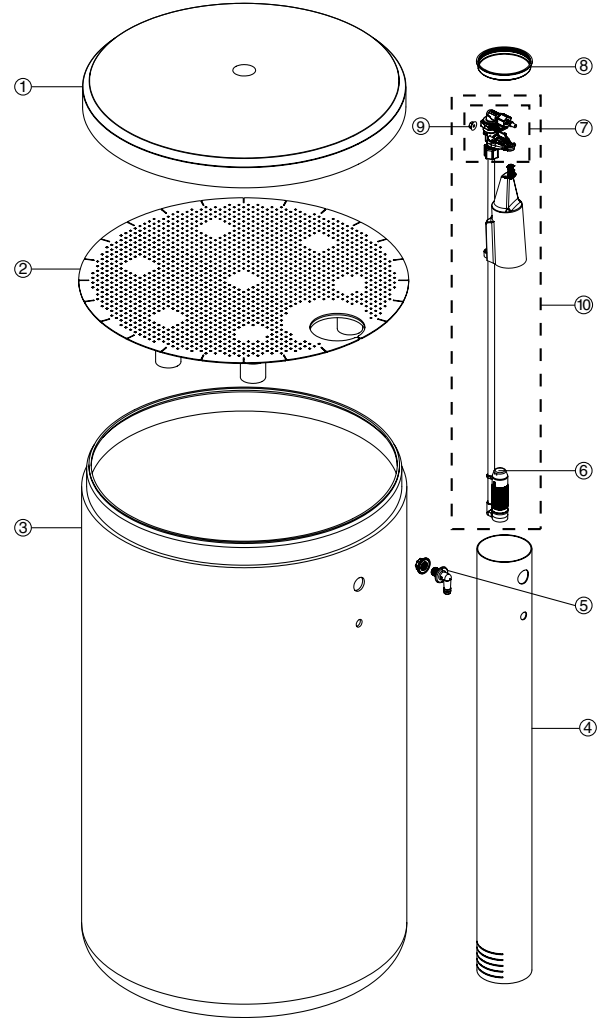

## SAFETY FLOAT BRINE ELBOW

Item #	Legacy Part #	Current Part #	Description	Qty.
	CV4144	100245015	3/8" elbow cap, Parker fitting (no flow control)	1
	CV4144-03	100242646	3/8" elbow cap, Parker fitting (w/flow control)	1
	CH4612	100245861	1/2" elbow cap	1

# INSTALLATION FITTING ASSEMBLIES

NOTE: Not all available fittings are displayed below. Contact manufacturer for optional fittings.

For All Assemblies

Item #	Legacy Part #	Current Part #	Description	Qty.
1	CV3151	100246287	Nut, 1" quick connect	2
2	CV3150	100246286	Split ring	2
3	CV3105	100246272	O-ring 215	2

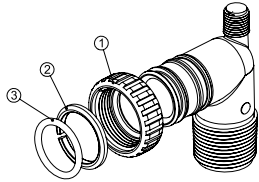

Legacy Part #	Current Part #	Description	Qty.
CV3007	100246197	1" PVC male NPT elbow assembly	2

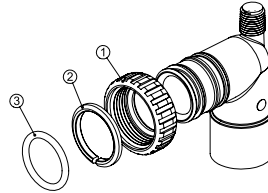

Legacy Part #	Current Part #	Description	Qty.
CV3007-01	100246198	3/4" & 1" PVC solvent elbow assembly	2

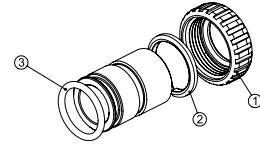

Legacy Part #	Current Part #	Description	Qty.
CV3007-02	100246199	1" brass sweat assembly	2

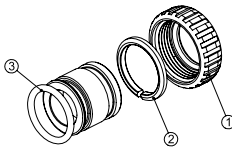

Legacy Part #	Current Part #	Description	Qty.
CV3007-03	100249846	3/4" brass sweat assembly	2

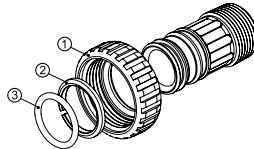

Legacy Part #	Current Part #	Description	Qty.
CV3007-04	100244506	1" plastic male NPT assembly	2

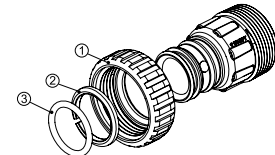

Legacy Part #	Current Part #	Description	Qty.
CV3007-05	100243921	1-1/4" plastic male assembly	2

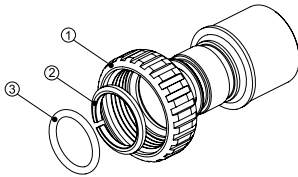

Legacy Part #	Current Part #	Description	Qty.
CV3007-09	100243922	1-1/4" & 1-1/2" brass sweat assembly	2

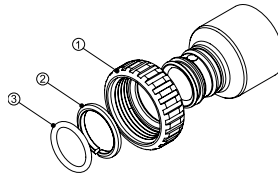

Legacy Part #	Current Part #	Description	Qty.
CV3007-07	100243375	1-1/4" & 1-1/2" PVC solvent assembly	2

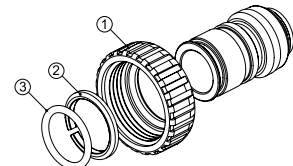

Legacy Part #	Current Part #	Description	Qty.
CV3007-12	100249847	3/4" brass shark bite assembly	2

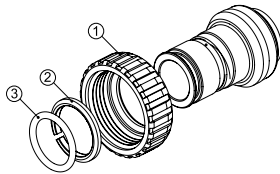

Legacy Part #	Current Part #	Description	Qty.
CV3007-13	100249848	1" brass shark bite assembly	2

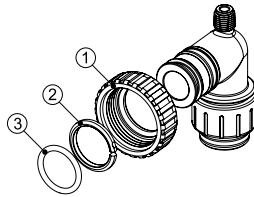

Legacy Part #	Current Part #	Description	Qty.
CV3007-15	100246200	3/4" john guest elbow assembly	2

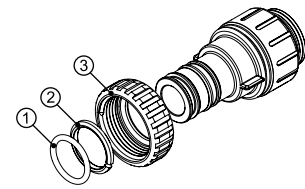

Legacy Part #	Current Part #	Description	Qty.
CV3007-17	100245045	1" john guest assembly	2

# SPECIFICATIONS:

## ES-Specifications

MODEL		ES-844	ES-948	ES-1044	ES-1054	ES-1252	ES-1354
Rated Softener Capacity:* (Grains/Lbs. Salt)	Minimum	13,700 @ 3.4	18,200 @ 4.5	18,200 @ 4.5	27,600 @ 7.0	36,400 @ 9.0	45,800 @ 11.5
	Medium	16,800 @ 6.0	23,500 @ 9.0	23,500 @ 9.0	36,700 @ 15.0	47,000 @ 18.0	53,900 @ 18.0
	Maximum	18,800 @ 8.0	28,000 @ 15.0	28,000 @ 15.0	42,000 @ 22.5	56,100 @ 30.0	69,800 @ 37.0
Efficiency at 1 lb Salt Setting (Grains/Lbs. Salt)		4,042/1	4,042/1	4,042/1	4,042/1	4,042/1	4,042/1
Max. Service Flow Rate (GPM)		11.7	13.1	16.0	13.3	16.4	17.1
Max. Pressure Loss at Max. Service (PSI)		15	15	15	15	15	15
Min. to Max. Working Pressure (PSI)		30-100	30-100	30-100	30-100	30-100	30-100
Min. to Max. Operating Temperature (°F)		33-100	33-100	33-100	33-100	33-100	33-100
Max. Flow to Drain During Regeneration (GPM)		1.3	1.7	2.2	2.2	3.2	3.2
Amount of High Capacity Cat-ion Resin (Cu. Ft.)		.75	1.0	1.0	1.5	2.0	2.5
Electrical Requirements (volts-hertz)		110-50/60	110-50/60	110-50/60	110-50/60	110-50/60	110-50/60
Pipe Size		1"	1"	1"	1"	1"	1"
Total Dimensions:	Media Tank and Valve	8"W x 52"H	9"W x 56"H	10"W x 52"H	10"W x 62"H	12"W x 60"H	13"W x 62"H
	Brine Tank	18"W x 33"H	18"W x 33"H	18"W x 33"H	18"W x 33"H	18"W x 40"H	18"W x 40"H



\*All Evolve ES water softeners are set at "medium salting" from the factory.



## Evolve Series® Water Softener Limited Warranty

Congratulations. You have purchased one of the finest water treatment systems available. In the unlikely event of a problem due to defects in material and workmanship, Water-Right® proudly warrants our Evolve Series® water softeners to the original owner, at original installation location, when installed in accordance with Water-Right specifications from the date of original installation as follows:

**For the LIFETIME of the original owner:** Media tank, except for damages due to freezing, high pressure (120 PSI and above), extreme temperature (100° F and above) or a vacuum on the system.

**For a period of TEN YEARS:** Brine tank.

**For a period of FIVE YEARS:** Complete valve.

**For a period of ONE YEAR:** All other parts and components.

Any part found defective within the terms of this warranty will be repaired or replaced by the dealer at the manufacturer's discretion. You pay only freight from our factory and local dealer charges. To obtain local warranty service, contact original dealer. If original dealer is unknown, contact Water-Right for authorized service dealer in your area. If no authorized dealer is located in your area, please ship defective part or component freight prepaid to:

Water-Right, Inc.  
1900 Prospect Ct.  
Appleton, Wisconsin 54914

Water-Right, at its discretion, will repair or replace the part or component at its expense and return part freight collect.

The above provisions of the warranty are valid as long as the unit is connected in compliance with local plumbing codes and in an equivalent manner and condition of the original installation and is owned by the original owner.

This warranty does not cover expendable or misapplied medias, or damages due to accident, fire, flood, freezing, or any other Act of God. Water-Right is not responsible for damages due to change in water conditions, misapplication, misuse, neglect, vacuum, oxidizing agents, alteration, or lack of maintenance. No responsibility is assumed for loss of use of the unit, inconvenience, loss or damage to real or personal property or any incidental or consequential damages. Furthermore, we assume no liability and extend no warranties, express or implied, for the use of this product with a non-potable water source. **To the extent permitted by law, Water-Right disclaims all implied warranties, including without limitation warranties of merchantability and fitness for particular purpose; to the extent required by law, any such implied warranties are limited in duration to the period specified above for the specified components.**

Some states do not allow limitations on how long an implied warranty lasts, so the above limitation may not apply to you. Some states do not allow the exclusion or limitation of incidental or consequential damages, so the above limitation or exclusion may not apply to you. This warranty gives you specific legal rights, and you may also have other rights which vary from state to state.



# QUICK REFERENCE GUIDE

## GENERAL OPERATION

When the system is operating, one of four displays will be shown:

1. Time of day/gpm
2. Flow rate
3. Capacity remaining
4. Days to a regen

Pressing **NEXT** will toggle between the four choices.

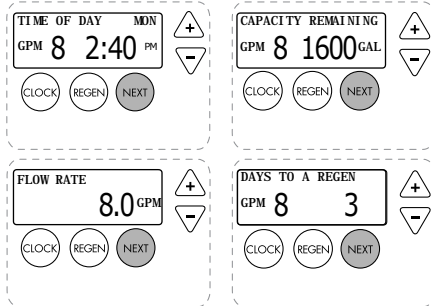

## TO SET TIME OF DAY

In the event of a prolonged power outage, time of day flashes, indicating that this needs to be reset. All other information will be stored in memory no matter how long the power outage.

1. Accessed by pressing **CLOCK**
2. Adjust hours with + or — buttons, AM/PM toggles at 12
3. Press **NEXT**
4. Adjust minutes with + or — buttons
5. Press **NEXT**
6. Adjust current day with + or — buttons
7. Press **NEXT** to complete and return to normal operation

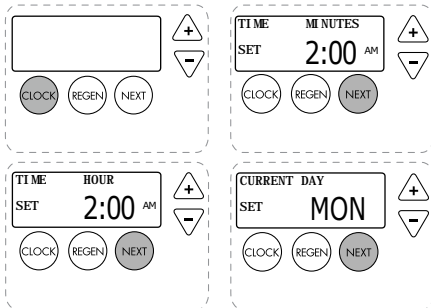

## MANUAL REGENERATION

**NOTE:** If you need to initiate a manual regeneration, either immediately, or the same night at the pre-programmed time for regeneration (typically 2:00 AM), complete the following steps.

### For Immediate Regeneration:

Press and hold **REGEN** until valve motor starts (typically 3 seconds).

### For Regeneration the same night:

Press and release **REGEN** (notice that flashing “REGEN TODAY” appears).

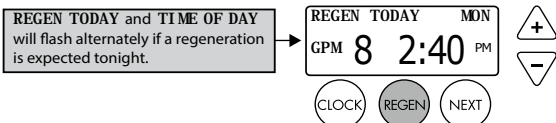

## ERROR

If the display toggles between “Error” and an error code (i.e. a number), call a service technician and report the error code.

CALL FOR SERVICE

**ERROR** 106

## BYPASS VALVE OPERATION

To shut off water to the system, position arrow handles as shown in the bypass operation diagram below. If your valve doesn't look like the diagram below, contact your service technician for instructions on how to shut off water.

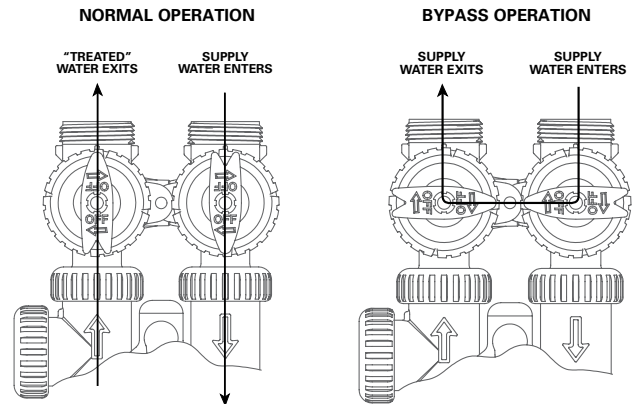

## ADJUST HARDNESS, DAYS BETWEEN REGENERATION, AND TIME OF REGENERATION

For initial set-up or to make adjustments, please complete the following steps.

1. Accessed by pressing **NEXT** and + button simultaneously
2. Adjust hardness using + or — buttons
3. Press **NEXT**
4. Adjust days between regenerations using + or — buttons
5. Press **NEXT**
6. Adjust time of regeneration hour with + or — buttons, AM/PM toggles at 12.
7. Press **NEXT**
8. Adjust time of regeneration minutes with + or — buttons
9. Press **NEXT**
10. Turn display backlight ON or OFF with + or — buttons. Default is ON.
11. Press **NEXT** to complete and return to normal operation.

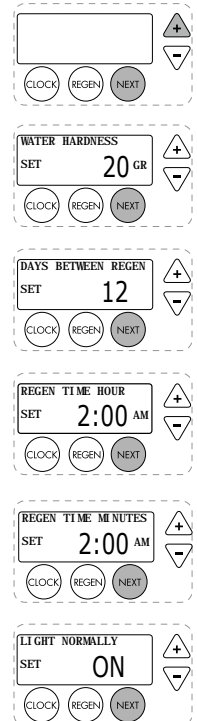

**NOTES**

**NOTES**



Manufactured exclusively for Evolve Dealers at:  
1900 Prospect Court • Appleton, WI 54914  
Phone: 920-739-9401 • Fax: 920-739-9406



Love your Evolve Softener?  
Scan the QR code above with  
your mobile device to leave  
a review.